

NITECORE®

The All-Round Flashlight Expert

P20UV User Manual

Features

- Features dual light sources: one main LED plus four secondary ultraviolet LEDs. Purpose built for authentication, forensics and identification applications.
- White Cree XM-L2 (U2) LED provides maximum output of 800 lumens
- Four ultraviolet LEDs provide 320mW at 365nm
- Maximum runtime of 15.5 hours on lowest output.
- Metal micro textured reflector provides a wide cone of peripheral light.
- Dual tail switches ensure ease of use and tactical advantages
- **STROBE READY™** provides direct access to strobe mode in any state (Chinese Patent: 201320545349.4)
- Features three selectable modes
- Tail switch features integrated power indicator to display remaining battery power (Chinese Patent: ZL201220057767.4)
- Anti-rolling design
- Two-way titanium steel clip included
- Toughened ultra-clear mineral glass with anti-scratch coating
- Constructed from aero grade aluminum alloy with HAIII military grade hard-anodized finish
- Waterproof in accordance with IPX8 (two meters submersible)
- Impact resistant to 1 meter

Dimensions

Length: 134mm (5.28")
 Bezel Diameter: 31.8mm (1.25")
 Tail Diameter: 25.4mm (1")
 Weight: 104grams (3.67oz)(without battery)

Accessories

Included: quality holster, CR123 battery magazine, clip, tactical ring, lanyard, spare O-ring
Optional: holster NTH30B, remote switch RSW2, tactical lanyard NTL10/NTL20

Battery Options

	TYPE	Nominal voltage	Compatible
Primary Lithium battery	CR123	3V	Y (Recommended)
18650 Rechargeable Li-ion battery	18650	3.7V	Y (Recommended)
Rechargeable Li-ion battery	RCR123	3.7V	Y

Brightness & Runtime

TEST STANDARD	HIGH	MED	LOW	UV	STROBE
800 LUMENS	400 LUMENS	70 LUMENS	—	800 LUMENS	—
3h30min	5h45min	15h30min	20h	—	—
180m	117m	48m	—	—	—
8100cd	3440cd	580cd	—	—	—
1m (Impact Resistant)					
IPX8, 2m (Waterproof AND Submersible)					

NOTE

The above data has been measured in accordance with the international flashlight testing standards ANSI/NEMAFL1 using 1 x 3.7V 2600mAh 18650 battery under laboratory conditions. The data may vary slightly during real-world use due to battery type, individual usage habits and environmental factors.

TEST STANDARD	HIGH	MED	LOW	UV	STROBE
800 LUMENS	400 LUMENS	80 LUMENS	—	800 LUMENS	—
1h30min	2h30min	8h	5h	—	—
180m	117m	54m	—	—	—
8100cd	3440cd	740cd	—	—	—
1m (Impact Resistant)					
IPX8, 2m (Waterproof AND Submersible)					

NOTE

The above data has been measured in accordance with the international flashlight testing standards ANSI/NEMAFL1 using 2 x 3V 1700mAh CR123 batteries under laboratory conditions. The data may vary slightly during real-world use due to battery type, individual usage habits and environmental factors.

Operation instructions

Battery Installation

Install one 18650 Li-ion battery or two CR123 Li-ion batteries with the positive pole pointing forward (toward the bezel).

NOTE: Integrated LEDs within the tail switch will blink to indicate remaining battery power after battery installation. Please refer to Power Tips for more information.

WARNING

1. Install batteries as instructed. Incorrect batteries installation will stop the torch from functioning.
2. The NBM1618 battery magazine holds 2 x CR123 batteries, inhibits batteries movement inside the compartment and helps maintain electrical continuity.
- 3 This product CANNOT be powered by flat-top batteries.
4. AVOID direct eye exposure.

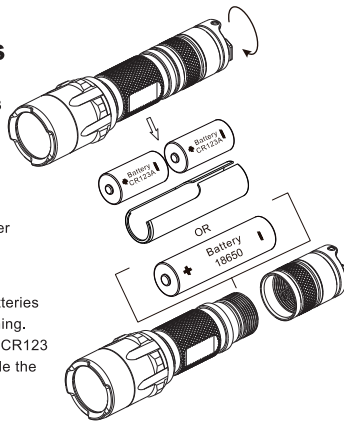

Momentary Illumination

Simply half press and hold the tail switch to turn on the flashlight, and release to turn it off.

Switching ON/OFF

To switch ON: press the tail switch until a "click" is heard;
 To switch OFF: with the light turned on, press the tail switch again until a "click" is heard.

Mode Selection

The P20UV offers three different modes of illumination for different users and situations:

Tactical Mode: this mode only provides turbo and ultraviolet outputs, and is ideal for self-defense, emergencies and tactical operations.

Law Enforcement Mode: this mode provides medium, turbo and ultraviolet outputs. This mode is designed for law enforcement officers and patrol guards.

General Mode (default mode for first time use): this mode provides low, medium, turbo and ultraviolet outputs. With the light turned on, press the **STROBE READY™** switch on the tail to cycle through all four outputs.

NOTE: 1. When using ultraviolet output, the P20UV is capable of sustaining a constant output for 13 hours with 1 x 3.7V 2600mAh 18650 Li-ion battery;

2. When in medium and turbo mode, the P20UV will reduce output luminance automatically after 3 minutes of use to prevent batteries from overheating and extends battery longevity.

⚠️ WARNING: Avoid eye or skin exposure to the ultraviolet light.

How to select a desired mode:

1. Ensure the P20UV is switched off.
2. Loosen the head of the torch.
3. Press and hold the **STROBE READY™** switch on the tailcap while simultaneously tightening the head.
4. Once the head has been tightened, the P20UV will indicate the mode that has been selected by flashing once for Tactical Mode, twice for Law Enforcement Mode and three times for General Mode.
5. To cycle through all three modes, simply repeat the above procedures.

Strobe Ready

1. With batteries loaded and the light turned off, press and hold **STROBE READY™** switch on the tailcap to enter Strobe mode. To exit, simply release the switch.
2. With the light turned on in any state, press and hold **STROBE READY™** switch on the tailcap for more than 0.5 second to enter strobe mode. To exit, simply press **STROBE READY™** switch again.

Note: This product has memory effect to ensure direct access to the last used brightness levels or strobe when resumed.

Power Tips

Two integrated LEDs built into the tail switch blink to indicate remaining battery power when the tail cap is tightened after battery installation. The power indicators will blink three times when power levels are above 50%; twice when power levels are below 50%; and once when battery power is close to depletion.

NOTE: When batteries are already installed and a precise power reading is required, ensure the P20UV is powered down for 20 seconds before retightening the tail cap to detect battery power status.

Replacing Batteries

Batteries should be replaced when any of the following occurs: The power indicators blink rapidly, output appears to be dim or the flashlight becomes unresponsive.

Maintenance

Every 6 months, threads should be wiped with a clean cloth followed by a thin coating of silicon-based lubricant.

Warranty Details

Our authorized dealers and distributors are responsible for warranty service. Should any problem covered under warranty occurs, customers can contact their dealers or distributors in regards to their warranty claims, as long as the product was purchased from an authorized dealer or distributor. NITECORE's Warranty is provided only for products purchased from an authorized source. This applies to all NITECORE products.

Any DOA / defective product can be exchanged for a replacement through a local distributor/dealer within the 15 days of purchase. After 15 days, all defective / malfunctioning NITECORE® products can be repaired free of charge for a period of 60 months (5 years) from the date of purchase. Beyond 60 months (5 years), a limited warranty applies, covering the cost of labor and maintenance, but not the cost of accessories or replacement parts.

The warranty is nullified if the product(s) is/are broken down, reconstructed and/or modified by unauthorized parties, or damaged by batteries leakage.

For the latest information on NITECORE® products and services, please contact a local NITECORE® distributor or send an email to service@nitecore.com.

※All images, text and statements specified herein this user manual are for reference purpose only. Should any discrepancy occurs between this manual and information specified on www.nitecore.com. Sysmax Industry Co., Ltd. reserves the rights to interpret and amend the content of this document at any time without prior notice.

SYSMAX inc.
 SYSMAX Industry Co., Ltd.
 TEL: +86-20-83862000
 FAX: +86-20-83882723
 E-mail: info@nitecore.com
 Web: www.nitecore.com
 Address: Rm 2601-06, Central Tower, No.5 Xiancun Road, Tianhe District, Guangzhou, 510623, Guangdong, China

Please find us on facebook:
 NITECORE Flashlight



Made in China

Thanks for purchasing NITECORE!